



**Environmental Health
Community Development Services**

Telephone: (719) 687-3048 • Fax: (719) 687-5256 ♦ P.O. Box 1886 • 540 Manor Court • Woodland Park, Co. 80866

**New Mobile Unit or Temporary Event
Establishment Packet**

Table of Contents

| Title | Description | Pages |
|-----------------------------|---|--------------|
| Cover Letter | Fees and general information | A, 1-2 |
| RFE APP | License Application | CR0002 |
| Contact Info Form | Administrative Information | B-1 |
| Vendor App | Licensee and Event Information | C-1 |
| Vendor Questionnaire | Food Safety and Preparation | D, 1-4 |
| Commissary | Affidavit of Commissary, Legal Doc | E-1 |
| Mobile Units | Chapter 9, Mobile Unit Regulations, <i>6 CCR 1010-12</i> | F, 1-4 |
| Temporary Events | Chapter 10, Temp Event Regulations, <i>6 CCR 1010-12</i> | G, 1-2 |
| Bare Hand Contact | Chapter 3, Bare Hand Contact with Ready-to-Eat Foods, <i>6 CCR 1010-12</i> | H-1 |
| Potentially Hazardous Foods | Appendix A, Defining Potentially Hazardous Foods, <i>6 CCR 1010-12</i> | I, 1-2 |
| Helpful Check List | Material and Equipment Checklist to Prepare for Event | J-1 |
| Calibrating a Thermometer | Helpful guidelines to calibrating a bimetallic probe thermometer | K, 1-2 |
| Hand Hygiene | 6 steps to proper and effective hand washing | L-1 |

Dear Licensee,

Teller County Environmental Health has made changes in licensing and inspecting your mobile unit or your vendor booth (temporary events). To make the review and inspection process as quick and trouble free as possible, please observe the following:

1. If you are renewing a mobile unit license for the current year in Teller County, you must call Joanne Guevara, Assistant Environmental Health Officer, at (719) 686-5416, to schedule an appointment for an inspection. All mobile unit inspections will be conducted at the Health Department, located in the Community Development Services, 540 Manor Court, Woodland Park, Co. 80863.
2. Before transporting the mobile unit to the Department, ensure refrigeration units, steam tables, and sinks are fully operational.
 - Coolers must have a cold holding temperature of 41° F or lower
 - Hot Holding units must have a hot holding temperature of 135° F or higher
 - Hot potable water must be available at the hand sink and 3-compartment sink
3. For first time applicants, a plan review and a pre-opening inspection must be scheduled with the Assistant Environmental Health Officer. Please have the following available:
 - Colorado Sales Tax Account Number
 - Fees: \$75.00 - Includes a Retail Food Establishment Application, Plan Review, and Pre-opening inspection (*Failure to submit an incomplete packet may result in assessment of additional fees*)- Fees are due prior to the pre-opening inspection
 - License Fees: \$154.00/year for Mobile Units
\$55.00/year for Mobile Units selling only pre-packaged products
\$154.00/year for Temporary/Special Events
\$55.00/year for Temporary/Special Events (pre-package)
 - Submit plans or a layout of the unit or booth
 - Equipment List: Manufacturer and Model number for each piece of equipment that will be utilized in the unit
 - Mechanical diagrams, including plumbing, kitchen ventilation and lighting (for mobile units only)
 - Complete Temporary Event/Mobile Unit Application
 - Copy of Menu
 - Signed Commissary Affidavit (*Commissaries must be from a current licensed facility in Teller County*)
 - Mobile unit must be transported to the Department at 540 Manor Court, Woodland Park, Co. 80863, for a pre-opening inspection

4. All temporary retail food establishments must comply with the Retail Food Establishments Rules and Regulations and register with the Department before attending a temporary event.

6 CCR 1010-2, 1-202 (67) Definitions:

Temporary Retail food Establishment means a food establishment that operates at a fixed location for a period of time of not more than fourteen (14) consecutive days in conjunction with a single event or celebration.

- Please submit application 2-3 weeks prior to event
- Licenses will be issued upon inspection at the event

Licensed facilities may operate a vending station in front of the facility without a temporary event license as long as the station is set up directly in front of the licensed facility. However, these facilities must comply with Chapter 10 of the Colorado Retail food establishment Rules and Regulations.

IMPORTANT NOTICE:

If there are public health hazards noted during an on-site inspection at an event and those hazards are not corrected immediately, the Department will not allow vendors to continue operation of temporary retail food establishments and will be asked to close the establishment.

If there are vendors who have not registered with the Department prior to the event, vendors must cease operation and will be asked to close the temporary retail food establishment.

For questions regarding this letter, please contact, Joanne Guevara at (719) 686-5416, guevaraj@co.teller.co.us

Thank you,

Joanne Guevara
Assistant Environmental Health Officer

Contact Information Form

| | | | |
|---|------|-----|-------|
| Colorado Sales Tax Account # | | | |
| Facility Name | | | |
| Facility Address, State, Zip | | | |
| Facility Phone | | Fax | |
| Full Legal Name of Corporation; individual owner or name of first partner | | | |
| Mailing Address, State, Zip | | | |
| 1st Contact | Name | | Title |
| Phone | Cell | Fax | |
| 2nd Contact | Name | | Title |
| Phone | Cell | Fax | |

Additional Information:

VENDOR APPLICATION FOR TEMPORARY EVENTS

All vendors must complete and submit to the Event Coordinator for each event in Teller County. If no menu and no equipment change are occurring from one event to another, the completed original may be copied and submitted. Please attach a copy of current temporary retail food establishment license, if applicable.

If you do not have a current Colorado Retail Food Establishment License, do not fill out this form. Contact the Teller County Health Department at (719) 687-3084 to begin the Plan Review and licensing process.

| | |
|--------------------|----------------------------|
| Event Name: | Dates of Operation: |
|--------------------|----------------------------|

Establishment Information

| | | | |
|-------------------------------|-------|------------------------------|--|
| Temporary Establishment Name | | Legal Owner Name | |
| Mailing Address | | | |
| City | State | Zip Code | |
| Facility Phone Number | | Fax Number | |
| Contact Person (During Event) | | Contact Number | |
| E-mail Address | | | |
| County Issuing License | | Colorado Sales Tax Account # | |

Unlicensed Licensed Temporary Event (provide copy) Licensed Mobile Unit (provide copy) Non-Profit (provide documentation)

If licensed in a different county, please attach a copy of the license.

Note: All vendors must have the Colorado Retail Food Establishment License on premises at all times.

Event Information

| | | | | | | | |
|-------------------------|-----|------|-----|-------|-----|-----|-----|
| Event Location: (venue) | | | | | | | |
| Hours of Operation: | | | | | | | |
| | Mon | Tues | Wed | Thurs | Fri | Sat | Sun |

Additional Events and Dates that you plan on attending in Teller County

| Event Name | Location | Date |
|------------|----------|------|
| | | |
| | | |
| | | |
| | | |

FOR HEALTH DEPARTMENT USE ONLY

- | | |
|---|--------------------------------------|
| <input type="checkbox"/> Licensed | <input type="checkbox"/> Approved |
| <input type="checkbox"/> License Needed | <input type="checkbox"/> Disapproved |
| <input type="checkbox"/> Non Profit | |

Environmental Health _____ Date _____

Comments: _____

B.) Once cooked, describe how cooked products will be cooled to 41°F in less than 6 hours:
(check all that apply)

- Shallow Pans, in cooler Ice bath, stirring occasionally
 Ice Wand/Paddle Other: (please specify) _____

C.) How will products be reheated to 165°F, if required, and what equipment will be used?
(check all that apply)

- Grill Oven Smoker Hotplate Microwave
 Other: (please specify) _____

3. While transporting food to the event, what equipment will be used to maintain food at 41°F or below? At 135°F or above?

- Ice chests with ice Cambros (cold holding)
 Cambros (hot holding) Distance (event less than 15 min. away)
 Other: (please specify) _____

4. What kind and how many food probe thermometers (0°F-220°F) will you have on site?

- Metal stem probe ____ Thermocouple ____ Digital ____

5. Food handling at the event: (please attach additional sheets if necessary)

List all menu items, including beverages, to be served. (check all that apply)

| Food | Cold Hold | Reheat | Cook | Hot Hold | Assemble | Other |
|------|-----------|--------|------|----------|----------|-------|
| | | | | | | |
| | | | | | | |
| | | | | | | |
| | | | | | | |
| | | | | | | |
| | | | | | | |
| | | | | | | |
| | | | | | | |
| | | | | | | |
| | | | | | | |

6. What equipment will be used on site to maintain product hot holding (135°F) and/or cold holding (41°F) temperatures?

Hot Holding Items

- Steam Table
 Cambros (hot holding)
 Crock Pot
 Held on grill until served
 Served immediately after cooking
 Deep Fryer
 Other: (please specify) _____

Cold Holding Items

- Ice Chest with ice
 Refrigerator
 Freezer
 Cambros (cold holding)
 Other: (please specify) _____

Note: Ice chests must be drainable and foods may not be kept in contact with the ice unless they are packaged and sealed.

7. What utensils will you use to dispense hot items?

8. What utensils will you use to dispense cold items?

9. What final assembly of food product will take place at the event?

10. Describe where and how frequently utensils and equipment will be washed, rinsed, and sanitized?

Commissary: _____ Commercial 3-compartment sink: _____

11. Liquid waste must be disposed of into a sanitary sewer system. Solid waste must be disposed into a dumpster. How will you dispose of your liquid and solid waste?

12. **HANDWASHING AND FOOD HANDLING:** A hand washing station within each booth or unit is required unless only prepackaged foods requiring no preparation and/or cooking are to be served. *(please check all that apply)*

I will be serving only prepackage foods that require no preparation and/or cooking

I will be serving foods that require preparation and/or cooking and will provide the following for hand washing:

A.) 2 gallons (minimum) of warm potable water that must be refilled as needed in a container with a "hands-free" spigot. *(Container must be able to provide free flowing water)*

B.) Liquid Soap

C.) Disposable paper towels

D.) 5 gallon (minimum) bucket to catch and contain waste water until it is properly disposed

*Note: Hand sanitizers are **not** an acceptable substitute for the required hand washing set-up.*

13. How will you prevent bare hand contact with ready-to-eat foods?

Food-grade disposable gloves Tongs Deli tissue

Other: *(please specify)* _____

14. Food must be protected from the public during preparation and storage. Describe how this will be done:

15. Please show a diagram of your mobile layout or vendor booth set-up. (*Include: Tables, equipment, washing facility, and customer access area*)

FOR HEALTH DEPARTMENT USE ONLY

Licensed

Approved

License Needed

Disapproved

Non Profit

Environmental Health _____ Date _____

Comments: _____

AFFIDAVIT OF COMMISSARY
MOBILE AND/OR TEMPORARY EVENT ESTABLISHMENTS

Date _____

I, _____ of _____, located at
(Owner/Operator) *(Licensed Commissary Establishment Name)*

(Address of Establishment, State, Zip Code)

do hereby offer the aforementioned establishment at the above address to

(Name of Mobile Unit/Temporary Event Establishment)

to utilize my licensed kitchen facilities to perform the following:

- Prepare foods such as vegetables, fruit, cutting of meat, cooking, cooling, reheating, etc.
- Store food, single service items, and cleaning agents
- Service and clean equipment
- Ware washing
- Fill water tanks
- Dispose waste water
- Other: *(please specify)* _____

Commissary Water Supply: Municipal Well
Commissary Sewage System: Municipal Septic

Indicate the equipment available at the commissary for proposed usage:

- Hand sink Food prep sink Mop sink 3-compartment sink
- Dish Machine Refrigeration Dry storage
- Other: *(please specify)* _____

I, _____ of _____
(Owner/Operator) *(Name of Mobile Unit or Temporary Establishment)*

offer this affidavit as proof that my food and products are prepared and stored in
_____, located at _____,
(Licensed Commissary Establishment Name) *(Address, State, Zip Code)*

which is currently licensed and under inspection by the Health Department. I acknowledge if I cease to use this facility or there is a change of ownership with the commissary, a new affidavit must be submitted to the Department for approval before I can resume selling my food product.

By signing below, I do hereby confirm that the above information is true.

Commissary Owner Signature _____
Date

Mobile Unit/Temporary Establishment Owner Signature _____
Date

CHAPTER 9

MOBILE RETAIL FOOD ESTABLISHMENTS OR PUSHCARTS

9-1 MOBILE RETAIL FOOD ESTABLISHMENT

9-101 General

Mobile retail food establishments or pushcarts shall comply with the requirements of these rules and regulations except as otherwise provided in this chapter. The Department may impose additional requirements to protect against health hazards related to the conduct of the mobile retail food establishment and may prohibit the sale of any potentially hazardous foods. If restrictions are imposed by the Department, they shall be in writing with a copy provided on the mobile unit at all times. A list of menu items prepared and/or served by the operator shall be submitted to the Department.

When no apparent health hazard will result, the Department may waive or modify requirements of this chapter relating to physical facilities, except those requirements of sections 9-104, 9-105, and 9-107 of these rules and regulations. Section 9-107(A) may be waived or modified when operating in accordance to chapter 10 of these rules and regulations.

9-102 Exemptions

Mobile retail food establishments or pushcarts are exempt from requirements for self-contained water or sewage systems, and cleaning and sanitization equipment under the following conditions:

- A. Food is prepared, then packaged in individual servings, transported and stored and served without further handling under conditions meeting the requirements of these rules and regulations; and
- B. Beverages served are not potentially hazardous and are dispensed from covered urns or other protected equipment; and
- C. The required equipment for cleaning and sanitization exists at the commissary.

9-103 Single-service Articles

Mobile retail food establishments or pushcarts shall provide only single-service articles for use by the consumer.

***9-104 Water System**

A mobile retail food establishment or a pushcart that does not meet the exemptions of section 9-102 of these rules and regulations shall provide hot and cold potable water under pressure with sufficient capacity for food preparation, utensil cleaning and sanitizing, in accordance with the requirements of these rules and regulations.

The water heater capacity shall be adequate to fill the three-compartment sink with 110°F water without interruptions at a minimum rate of 1 gallon per minute with reserve capacity to provide a minimum of 3 gallons per hour of warm water to all handsinks at all times.

The water inlet shall be located so that it will not be contaminated by waste discharge, road dust, oil, or grease, and it shall be kept capped unless being filled. The water inlet shall be provided with a transition connection of a size or type that will prevent its use for any other service. All water distribution pipes or tubing shall be constructed and installed in accordance with the requirements of these rules and regulations.

When a mobile retail food establishment is connected to a pressurized water supply, it shall be provided with approved backflow prevention devices. This shall include the protection of the water source as well as protection of each individual water service connection.

The water supply hose and couplings shall be of a size and type compatible with the water supply tank inlet fixture and shall be free of cracks and checks. Hose couplings shall be constructed to permit a tight connection between the mobile retail food establishment coupling and the water supply hose bib. Hose ends must be capped, connected or otherwise fully protected when not being used.

9-105 Wastewater Retention

*A. All liquid waste, except drainage from clean potable ice, generated by a mobile retail food establishment or pushcart shall be stored in a retention tank that is at least 15 percent larger than the water supply tank. Liquid waste shall be discharged from the retention tank to an approved sewage disposal system and flushed as often as necessary to maintain sanitary conditions. Discharge onto the surface of the ground shall be strictly prohibited. Drainage from clean potable ice can be discharged onto the surface of the ground provided it does not create a nuisance.

B. All connections on the vehicle for servicing mobile food unit waste disposal facilities shall be of a different size or type than those used for supplying potable water to the mobile food establishment. The waste connection shall be located lower than the water inlet connection to prevent contamination of the potable water system.

C. Liquid waste discharge piping and the potable water hose shall not be stored in a manner that may result in cross-contamination.

***9-106 Handwashing Facilities**

A mobile retail food establishment or pushcart that does not meet all the restrictions of section 9-102 of these rules and regulations must be equipped with a convenient, accessible handsink for employee handwashing. The handsink must be capable of providing a hands-free, continuous flow of warm water. The handsink must be of adequate pressure and size to facilitate proper handwashing. Soap and individual paper towels must also be provided.

***9-107 Commissary**

A. The commissary is considered to be an essential part of the mobile food establishment operation. The commissary shall be constructed and operated in compliance with the requirements of these rules and regulations. Mobile retail food establishments or pushcarts shall operate from a commissary or other fixed retail food establishment and shall report every 24 hours (on operational days) to that location for all supplies and for all cleaning and servicing operations. The mobile retail food establishment operator shall verify to the Department in writing that the mobile unit returns to the commissary every 24 hours.

B. A mobile retail establishment servicing area shall be provided and shall include a potable water supply. A servicing area is an operating base location to which a mobile food establishment or transportation vehicle returns regularly for such things as vehicle and equipment cleaning, discharging liquid or solid wastes, refilling water tanks and ice bins, and boarding food.

1. Within this servicing area, there shall be a location provided for the flushing and drainage of liquid wastes that is separate from the location provided for potable water servicing and for the loading and unloading of food and related supplies. This servicing area will not be required where only packaged food is placed on the mobile food unit or pushcart, or where mobile food units do not contain waste retention tanks.

2. Potable water servicing equipment shall be installed according to the law and shall be stored and handled to protect the water and equipment from contamination.

3. The mobile retail food establishment liquid waste retention tank shall be thoroughly flushed and drained during the servicing operation. All liquid waste shall be discharged to a sanitary sewage system in accordance with section 5-211 of these rules and regulations.

4. The floor surface of the servicing area shall be constructed of a smooth, nonabsorbent material such as concrete or machine-laid asphalt and shall be maintained in good repair, kept clean, and be graded to drain.

5. The construction of the walls and ceilings of the servicing area is exempt from the provisions of sections 6-201 and 6-202 of these rules and regulations.

C. A fully equipped, mobile retail food establishment shall not be required to report to a servicing area if:

1. The mobile retail food establishment's potable water system and waste retention system is sufficiently sized or operated properly to serve the needs of the mobile retail food establishment and, and liquid waste is emptied only at service locations approved by the Department; and

2. The mobile retail food establishment is capable of being maintained in a sanitary condition; and

3. Adequate storage areas are provided within the mobile retail food establishment for food, dry goods, single service articles and cleaning supplies; and

4. Adequate facilities are provided for food preparation, for cleaning and sanitizing of equipment and utensils, for the storage of additional food, equipment, utensils and other supplies, and for other servicing operations; and
5. Approved arrangements and facilities are provided and used to supply potable water to the mobile unit for the disposal of wastewater generated by the establishment; and
6. A written operational plan is submitted by the mobile retail food establishment, which demonstrates that this process can be accomplished in compliance with these rules and regulations. Review and approval of this plan must include the menu and standard operating procedures for the mobile unit. Once an operational plan is approved, any additions or changes to the approved plan must be approved by the Department prior to implementation.

9-108 Additional Requirements

Spare tires, tools, and other equipment relating to the mechanical operation of the vehicle shall be stored in a way that does not contaminate food, food equipment, or utensils.

CHAPTER 10

TEMPORARY RETAIL FOOD ESTABLISHMENTS

10-1 TEMPORARY RETAIL FOOD ESTABLISHMENTS

10-101 General

A temporary retail food establishment shall comply with the requirements of these rules and regulations, except as otherwise provided in this chapter.

A list of menu items used by the operator shall be submitted to the Department. The Department may impose additional requirements to protect against health hazards related to the conduct of the temporary retail food establishment and may prohibit the sale of any potentially hazardous foods. When no apparent health hazard will result, the Department may waive or modify requirements of these rules and regulations.

***10-102 Restricted Operations**

Only potentially hazardous foods requiring preparation limited to seasoning and cooking shall be served. The preparation or service of other potentially hazardous foods, including pastries filled with cream or synthetic cream, custards and similar products, salads or sandwiches containing meat, poultry, eggs, or fish, is prohibited unless approved, and adequate equipment and facilities are provided. This prohibition does not apply to any potentially hazardous food prepared and packaged under conditions meeting the requirements of these rules and regulations, obtained in individual servings, stored at a temperature of 41°F (5°C) or below, or at a temperature of 135°F (57°C) or above in facilities that meet the requirements of these rules and regulations, and is served directly in the unopened container in which it was packaged.

***10-103 Ice**

Ice that is consumed or that contacts food shall be made under conditions meeting the requirements of these rules and regulations. Ice obtained off site shall be only in chipped, crushed, or cubed form and in single-use safe plastic or wet-strength paper bags filled and sealed at the point of manufacture.

10-104 Equipment

A. Equipment shall be located and installed to prevent food contamination and to facilitate cleaning the establishment.

B. Food-contact surfaces of equipment shall be protected from contamination by consumers and other contaminating agents. Effective shields for such equipment shall be provided as necessary to prevent contamination.

10-105 Single-Service Articles

All temporary retail food establishments, which do not have approved facilities for cleaning and sanitizing tableware, shall provide only single-service articles for use by the consumer.

***10-106 Water**

A sufficient quantity of potable water shall be available for food preparation and sanitization of food-contact surfaces. The water supply system hoses, piping, and appurtenances must be approved food-contact materials. The water supply system must be installed to preclude the backflow of contaminants into the potable water supply.

10-107 Wet Storage

Packaged food may be stored in direct contact with potable ice or potable water if the packaging, wrapping, or container is not subject to entry of water.

***10-108 Waste**

All sewage, including liquid waste, shall be disposed of according to law. Drainage from clean potable ice can be discharged onto the surface of the ground provided it does not create a nuisance.

***10-109 Handwashing**

A conveniently located handwashing facility shall be available for employee handwashing. This facility must be capable of providing a hands-free, continuous flow of warm water. The handwashing facility must be of adequate pressure and size to facilitate proper handwashing. Soap and individual paper towels must also be provided.

10-110 Floors

Floors shall be constructed of concrete, asphalt, tight wood, or other similar material kept in good repair. Dirt or gravel, when graded to drain, may be used as sub-flooring when covered with clean, removable platforms or duckboards, or covered with wood chips, shavings, grass or other suitable materials to control dust.

10-111 Walls and Ceilings

A. Ceilings shall be made of wood, canvas, or other materials that protect the interior of the establishment from the weather. Walls and ceilings shall be constructed in a way that prevents the entrance of insects. Doors to food preparation areas shall be solid or screened and shall be self-closing. Screening material used for walls, doors, or windows shall be at least 16 mesh to the inch (16 mesh to 25.4 mm).

B. Counter-service openings shall not be larger than necessary for the particular operation conducted. These openings shall be provided with tight-fitting, solid or screened doors or windows, or shall be provided with fans installed and operated to restrict the entrance of flying insects. Counter-service openings shall be kept closed, except when in actual use. Screening of walls, doors and outer openings do not apply if flying insects and other pests are absent due to the location of the establishment, the weather, or other limiting condition.

CHAPTER 3

3-3 PROTECTION FROM CONTAMINATION AFTER RECEIVING

Bare Hand Contact with Ready-to-Eat Foods

***3-301 Preventing Contamination from Hands (Effective March 1, 2007)**

- A. Food employees shall wash their hands as specified under §2-402.
- B. Food employees shall minimize bare hand and arm contact with exposed food that is not in a ready-to-eat form.
- C. Except when washing fruits and vegetables as specified under §3-305(a) or except as specified in (D) of this section, food employees may not contact exposed, ready-to-eat food with their bare hands and shall use suitable utensils such as deli tissue, spatulas, tongs, single-use gloves, or dispensing equipment.

APPENDIX A - Potentially Hazardous Foods

"Potentially Hazardous Food" means any food or food ingredient, natural or synthetic, in a form capable of supporting the rapid and progressive growth of infectious or toxigenic microorganisms or the slower growth of C. botulinum.

A food is potentially hazardous: a) if it is of animal origin such as meat, milk, fish, shellfish, edible crustacea, or poultry; or b) if it is of plant origin and has been heat treated; or c) if it is raw seed sprouts. The following is a limited list of specific food products that have been classified to be potentially hazardous.

1. Bacon - If it has not been fully cooked.
2. Balutes - Fertile eggs, generally chicken or duck eggs, which are incubated for a period of time shorter than is necessary for hatching. The developing embryo is incubated generally 14 to 18 days and is considered a delicacy by various ethnic populations when eaten raw or cooked.
3. Beans - All types of cooked beans.
4. Whipped Butter - Hazardous because of the apparent reduced microbiological safety factor created by whipping.
5. Cheese - Soft unripened cheese. Ripened, low moisture hard cheese such as wheels, flats, blocks or longhorns of cheddar cheese produced from pasteurized milk, when waxed or packaged in "shrink" wrapping with the wax or packaging intact, can be safely shipped or stored for a short period of time without refrigeration but it is not recommended. If wheels, flats, blocks, longhorns, or any other forms of cheese have been damaged, cut and repackaged for display and/or sale, thereby exposing interior surfaces to possible contamination, the cut portions as well as the remaining cheese shall be held under refrigeration.
6. Coffee Creaming Agents - All non-dairy coffee creaming agents in liquid form, except aseptically processed ultra high temperature (UHT) liquid coffee creaming agents.
7. Eggs - Cooked, cracked, fresh with outer shell removed, peeled hard-boiled eggs, and hard-boiled eggs with intact shells which have been hard-boiled and then cooled in liquid. Refrigeration of raw whole eggs in the shell is required.
8. Garlic - Garlic in oil products.
9. Mayonnaise or Other Acidified Salad Dressings - If the pH is above 4.6 and/or combined with other food products.
10. Onions - Cooked and dehydrated that have been reconstituted.
11. Pasta - All types that have been cooked.

12. Pastries - Meat, cheese and cream filled. A – 2
13. Pies - Meat, fish, poultry, natural cream, synthetic cream, custard, pumpkin and pies that are covered with toppings which will support microbial growth.
14. Potatoes - Baked, boiled or fried.
15. Rice - Boiled, steamed, fried, Spanish and cooked rice used in sushi.
16. Sauces - Hollandaise and other sauces, containing potentially hazardous ingredients. If these are held in the temperature range of 41 F (5 C) to 135°F (57 C), they must be discarded within four hours of preparation.
17. Sour Cream - If the pH is above 4.6 and/or combined with other food products.
18. Soy Protein - Tofu and other moist soy protein products.
19. Seed Sprouts - All types.

Foods Which Are Not Potentially Hazardous Are:

1. Hard-Boiled eggs with shells intact which have been air-dried;
2. Foods with a water activity (a_w) value of 0.85 or less;
3. Foods with a measurement of acidity (pH) of 4.6 or below;
4. Foods which have been adequately commercially processed and remain in their unopened hermetically sealed container; and
5. Food for which laboratory evidence (acceptable to the regulatory authority) demonstrates that rapid progressive growth of infectious and toxigenic microorganisms or the slower growth of C. botulinum cannot occur.

Temporary Event/Mobile Unit Retail Food Establishment Check List

- ___ Current valid Retail Food Establishment License (Pink) for “Temporary Events” or “Mobile Units”
- ___ Hand washing station set-up: Water (free flowing, with spigot), catch bucket, liquid soap, and paper towels
- ___ Food probe thermometer (0°F-220°F) to test the internal temp of product
- ___ Sanitizing Solution or bucket: Must contain chlorine agent or quaternary ammonia agent
- ___ Sanitizing Test Strips: Chlorine (White strips that turn purple upon contact: 50ppm-200ppm) or Quaternary ammonia (Orange Test Strips that turn green upon contact: 100ppm-200ppm); depending on the agent being used
- ___ Coolers to keep potentially hazardous food cold (41°F or lower)
- ___ Warmers to keep potentially hazardous hot (135°F or lower)
- ___ Ensure employees are not touching Ready-to-eat foods with bare hands. Ready-to-eat foods examples (food that will not undergo further preparation as far as cooking):
 - Baked bread
 - Tacos/Burritos/tamales, ect...
 - Sandwiches
 - Salad
 - Garnishes
- ___ Proper utensils with handles, pastry paper, gloves, etc... to prevent bare hand contact to ready-to-eat-foods

Vendors that need retail food establishment licenses:

Pre-packaged potentially hazardous foods: ice cream, sandwiches, burritos, nuts, hermetically sealed (canned or jarred) jams/preservatives, raw meats, cooked meats...

****Chips, candy, soda, fundraising bake sales, school related activities... Exempt****

Full Service Establishments

Medium Service Establishments

Calibrating a Thermometer

There are two ways to check the accuracy of a food thermometer. One method uses ice water, the other uses boiling water. Many food thermometers have a calibration nut under the dial that can be adjusted. Check the package for instructions.

Ice Water

To use the ice water method, fill a large glass with finely crushed ice. Add clean tap water to the top of the ice and stir well. Immerse the food thermometer stem a minimum of 2 inches into the mixture, touching neither the sides nor the bottom of the glass. Wait a minimum of 30 seconds before adjusting. (For ease in handling, the stem of the food thermometer can be placed through the clip section of the stem sheath and, holding the sheath horizontally, lowered into the water.) Without removing the stem from the ice, **hold the adjusting nut under the head of the thermometer with a suitable tool and turn the head so the pointer reads 32 °F.**

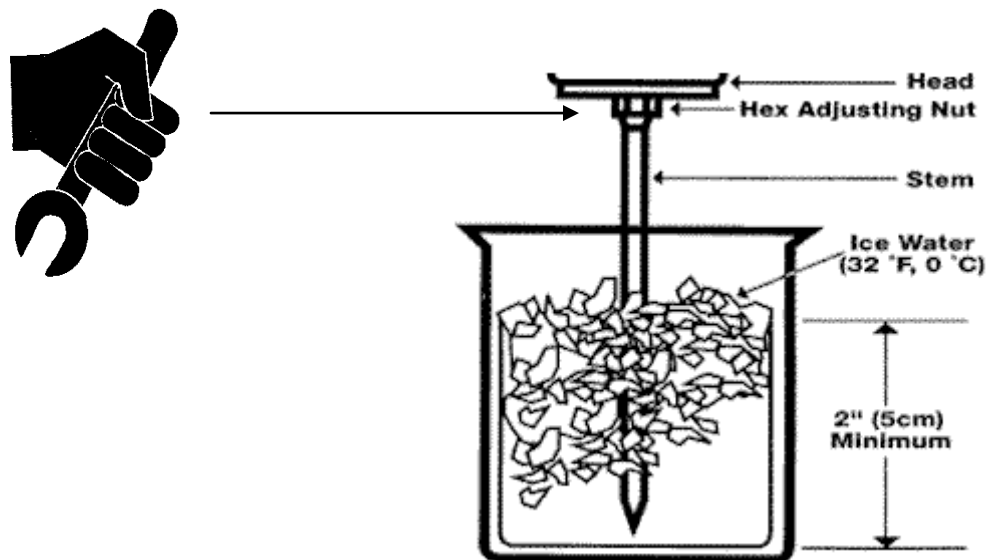

"Is it **done** yet?" You can't tell by **looking**. Use a **food thermometer** to be sure.
www.IsItDoneYet.gov

http://www.fsis.usda.gov/Fact_Sheets/Kitchen_Thermometers/index.asp

Boiling Water

To use the boiling water method, bring a pot of clean tap water to a full rolling boil. Immerse the stem of a food thermometer in boiling water a minimum of 2 inches and wait at least 30 seconds. (For ease in handling, the stem of the food thermometer can be placed through the clip section of the stem sheath and, holding the sheath horizontally, lowered into the boiling water.) Without removing the stem from the pan, **hold the adjusting nut under the head of the food thermometer with a suitable tool and turn the head so the thermometer reads 212 °F.**

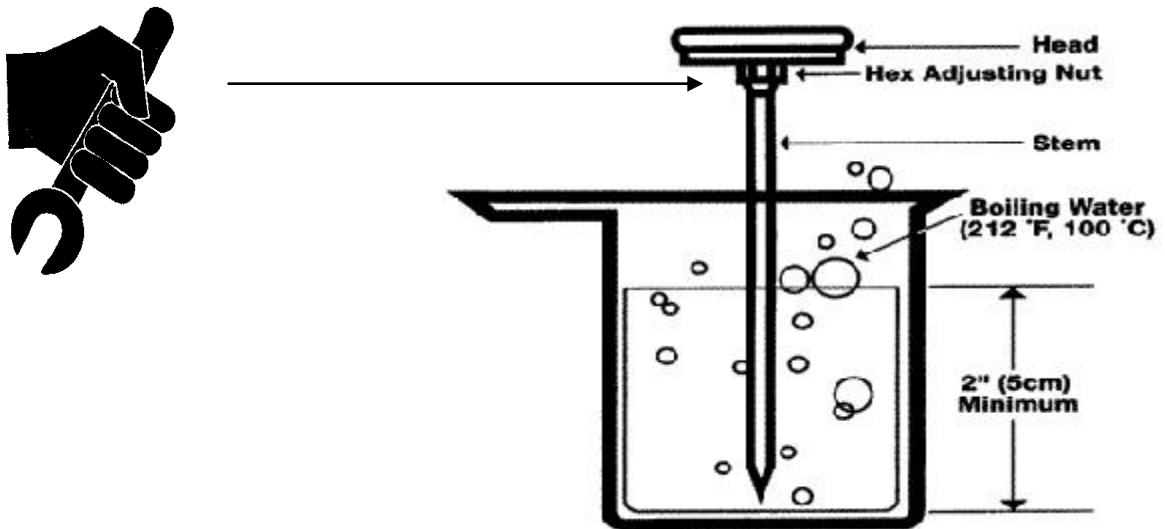

"Is it **done** yet?" You can't tell by **looking**. Use a **food thermometer** to be sure.
www.IsItDoneYet.gov

http://www.fsis.usda.gov/Fact_Sheets/Kitchen_Thermometers/index.asp

6 Easy Steps to Hand Washing



When to wash: *Before preparing food, employees must wash hands thoroughly:*

- after using the bathroom
- after eating and drinking
- after smoking
- after switching from raw meats to ready-to-eat foods
- after touching bare human body parts other than clean hands and clean arms
- after and during food preparation; as often as necessary to remove soil and contamination and to prevent cross-contamination when changing tasks
- before donning single use gloves and between changing gloves
- handling soiled equipment or utensils
- after handling animals
- after engaging in any activity that may contaminate the hands
- after handling fish in aquariums, shellfish, or crustacean in display tanks